

RADIAL
1250 · 900 · 600P3S

RN
900 · 700 · 450

SQUADRATRICI RADIALI

WOOD be nice.

OMGA



RADIAL

1250 · 900

SERIE RADIAL

Linea pesante della gamma con braccio in ghisa.
 Guide di scorrimento prismatiche riportate (A), quindi facilmente intercambiabili, scorrimento del gruppo su otto cuscinetti (B) dotati di raschiapolvere. Bloccaggi autocentranti sia della rotazione del braccio che dell'inclinazione del motore. Sponde in alluminio. Possibilità di montare l'avanzamento oleopneumatico.

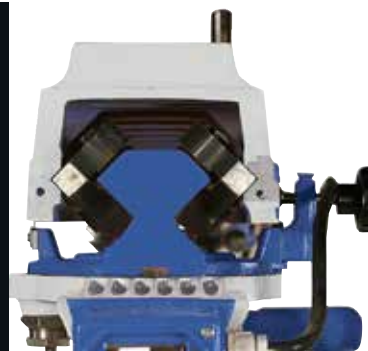

A



B



RADIAL1250 VERSION CE

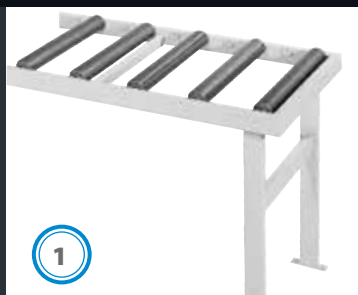

1

Banco a rulli (2000 / 3000 mm)



2

Protezione per frese (300x60 mm)



3

Prolunga sponda (1000 / 2000 / 3000 / 4000 mm)



4

Ritorno automatico



5

Pressori pneumatici

OPTIONAL



RADIAL 900

Avanzamento oleopneumatico



Pressore frontale

Sollevamento anteriore (R 900)

Alberi speciali (Ø 30x60)

Fermo mobile (R 1250 - 900)

Fermo mobile pneumatico (R 1250 - 900)

6



RADIAL 600P3S

SERIE RADIAL

Linea industriale della gamma con braccio in ghisa.
Guide di scorrimento prismatiche (A) facilmente intercambiabili, scorrimento del gruppo su otto cuscinetti dotati di raschiapolvere (B). Bloccaggi autocentranti sia della rotazione del braccio che dell'inclinazione del motore. Sponde in legno. Possibilità di montare avanzamento oleopneumatico.



A



B



RADIAL 600P3S

OPTIONAL

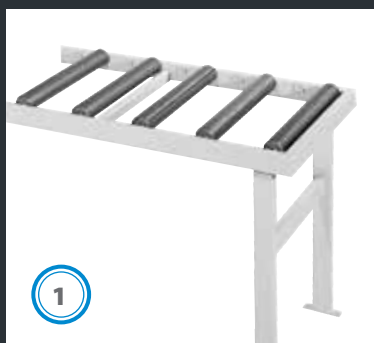

1

Banco a rulli (2000 / 3000 mm)



2

Protezione per frese (300x60 mm)



3

Ritorno automatico

Alberi speciali (Ø 30x60)



RADIAL 600P3S VERSION CE

Avanzamento oleopneumatico



Pressore frontale



RN

900 · 700 · 450

SERIE RN

Linea industriale della gamma con braccio in alluminio. Guide di scorrimento in acciaio intercambiabili, scorrimento del gruppo su otto cuscinetti (A) dotati di raschiapolvere. Lo sbloccaggio del braccio avviene facilmente tramite una leva posta sulla parte frontale del braccio stesso. Bloccaggi autocentranti sia della rotazione del braccio (B) che dell'inclinazione del motore. Sponde in legno.



RN900
VERSION CE



A



B



RN700



Banco a rulli (2000 / 3000 mm)





Protezione per frese (300x60 mm) no CE



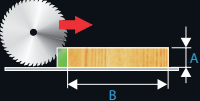

Ritorno automatico

	RADIAL 1250	RADIAL 900	RADIAL 600P3S	RN 900	RN 700	RN 450
--	-------------	------------	---------------	--------	--------	--------

	mm	A = 30 - 125 B = 1250 - 1170	A = 34 - 125 B = 900 - 825	A = 38 - 90 B = 600 - 505	A = 32 - 90 B = 900 - 825	A = 32 - 90 B = 450 - 390
---	----	---------------------------------	-------------------------------	------------------------------	------------------------------	------------------------------

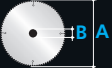
	mm	A = 125 B = 1170	A = 125 B = 825	A = 90 B = 505	A = 90 B = 825	A = 90 B = 390
---	----	---------------------	--------------------	-------------------	-------------------	-------------------

	mm RPM	A = 400 B = 30 3000	A = 400 B = 30 3000	A = 300 B = 30 3000	A = 300 B = 30 3000	A = 300 B = 30 3000
---	-----------	---------------------------	---------------------------	---------------------------	---------------------------	---------------------------

	kW	3,7 - 5,5	3,7 - 5,5	2,9	2,9	2,9
---	----	-----------	-----------	-----	-----	-----

	∅ mm	120	120	120	120	120
---	------	-----	-----	-----	-----	-----

	N (newton)	4165	3600	1940	2110	1780	1380
---	---------------	------	------	------	------	------	------

	LxWxH mm	2150x1520x1050	1900x1320x1100	1550x440x1080	1700x500x1280	1150x440x1100	1550x440x1100
---	-------------	----------------	----------------	---------------	---------------	---------------	---------------

H = 1400	H = 1625	H = 1300	H = 1545	H = 1545	H = 1450
L = 1400	L = 1060	L = 1085	L = 1085	L = 900	L = 840
L' = 2050	L' = 1650	L' = 1485	L' = 1485	L' = 1290	L' = 1030
W = 1400	W = 1190	W = 900	W = 1215	W = 900	W = 800
mm W' = 4800 CE	W' = 4190 CE	W' = 2750 CE	W' = 3095 CE	W' = 2750 CE	W' = 2490 CE

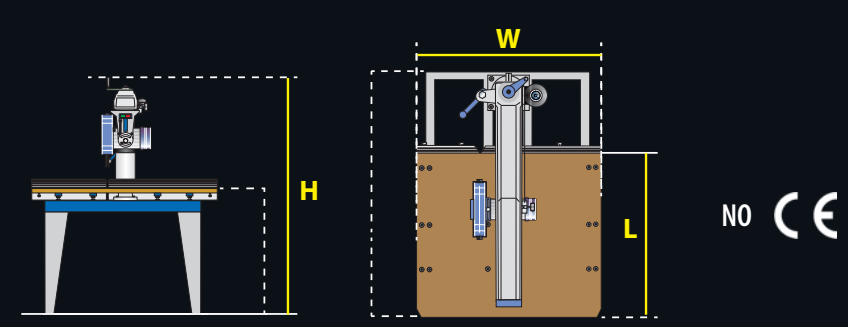
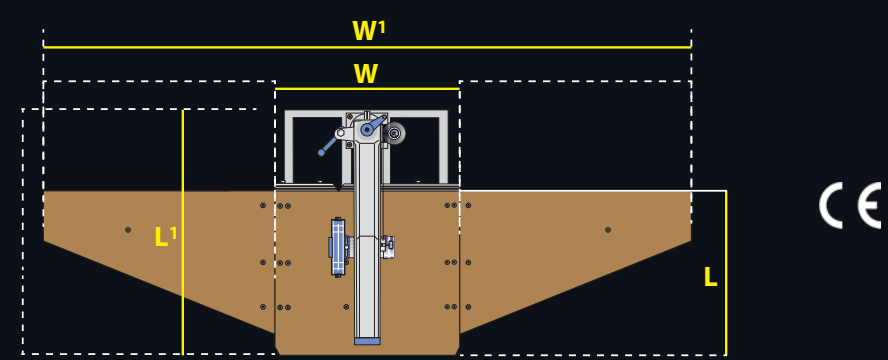
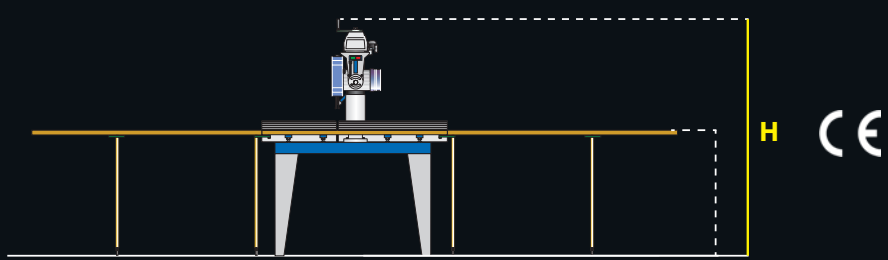

 2900204565.03

DIERREGI SRL
 VIA DELLA SCIENZA 5
 41012 CARPI (MO) - ITALY
 PHONE: +39.059.803.0103
 FAX: +39.059.803.0113
 COD. FISCALE E P.IVA:
 IT 03601330362

WWW.OMGA.IT



Tutte le informazioni e i dati sono soggetti a modifiche senza preavviso.