

FP

N.C. POSITIONIERANSCHLAG

WOOD be nice.

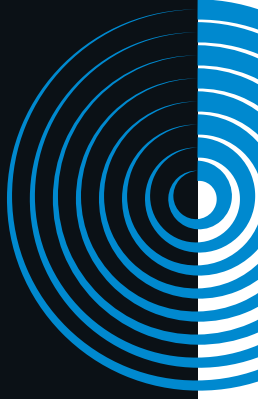

OMGA



RADIAL 900 (mit FP)



T 50 350 OP (mit FP)



FP

N.C. POSITIONIERANSCHLAG

Elektronischer Positionieranschlag, lieferbar in Längen von 2 bis 6 Metern, mit einem breiten Anwendungsspektrum, sowohl in Verbindung mit OMGA- Maschinen, als auch mit Fremdfabrikaten. Steuerung mit 7-Zoll Touchscreen und der Möglichkeit, Schneidelisten auf Micro-SD Karte zu speichern. Der Ethernet-Anschluss RJ45 ermöglicht die Anbindung an einen externen PC. Mit USB-Schnittstelle für die Programmierung und für Aktualisierungen.

Die Software ist für drei unterschiedliche Anwendungen verfügbar: Positionieranschlag, programmierbarer Schieber und für das Schneiden von Bilderrahmenleisten.

Der Anschlag kann mit Auflagetischen und Rollenbahnen unterschiedlicher Breite, verschiedenen Endstücken (gefederter Anschlag 90°, Spannzange oder 45° - Anschlag), sowie mit mechanischen und elektrischen Verbindungssätzen vervollständigt werden.



OPTIONAL

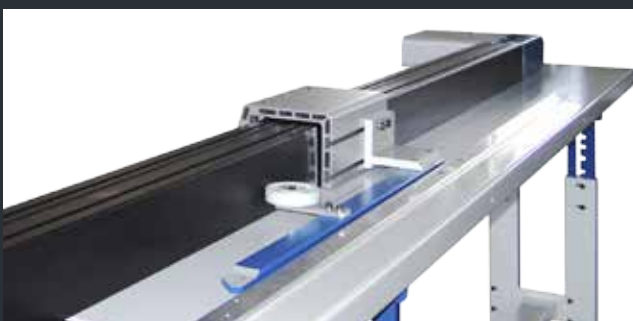

Anschlag 45° (V235 FNC)



Inkrementeller Magnetsensor



Stoßgedämpfter Längensanschlag: RECHTS oder LINKS



Anbausatz

V 235 FNC (mit FP)

OMGA®
WOOD be nice.

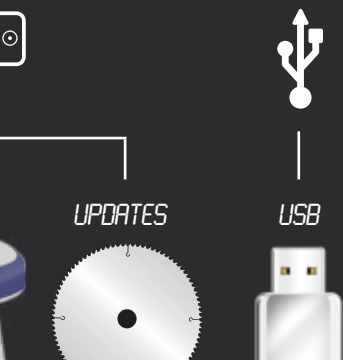

UPDATES

USB

SOFTWARE

- Längenanschlag
- Programmierbarer Vorschub
- Längenanschlag für Rahmen



3000

2000

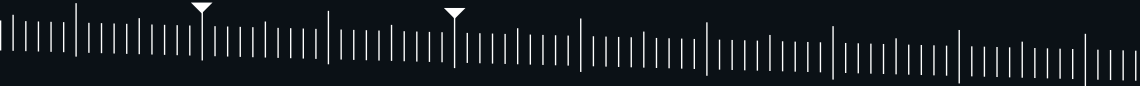

für Kappsäge

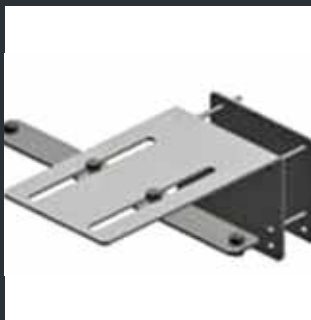

Anbausatz für Radialsäge





Sicherheitssatz



Etikettendrucker



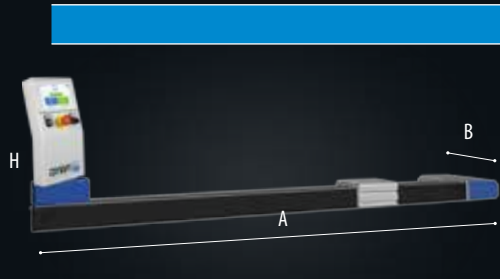

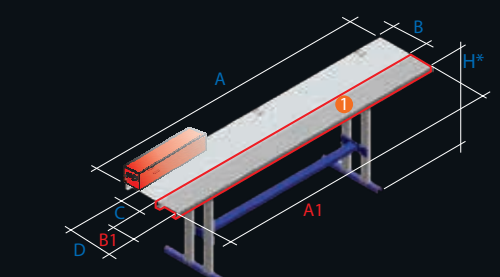

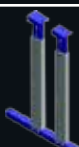
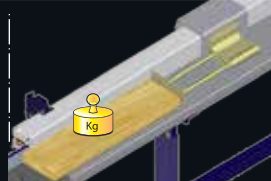
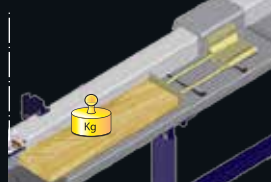

Barkodelesegerät

	mm	FP 2000	FP 3000	FP 4000	FP 5000	FP6700
	A	2743	3743	4743	5743	7443
	B	490				
	C	600				
		495	605	715	825	1010
	A	2680	3680	4680	5680	7360
	B	345				
	C	235				
	A1	2680	3680	4680	5680	--
	B1	205				
	D	440				
	H*	* 800 - 1000				

 Tischverbreiterung

	A	2700	3700	4700	5700	7400
	B	350 KAPPSÄGEN				
		600 RADIALSÄGEN				
	C	240 KAPPSÄGEN				
		490 RADIALSÄGEN				
	H	* 800 - 1000				
		1100	1320	1870	2200	2400
		KAPPSÄGEN				
		1520	1860	2630	3040	3400
		RADIALSÄGEN				

	Füße regulierbar auf drei schon festgelegten Höhen oder nach Wunsch
	kg 50
	kg 70
	Vorschubgeschwindigkeit 60 m/min
	1,0 kw - 110 / 230 V 10 / 5 A - 50 / 60 Hz
	Betriebstemperatur 5° ÷ 45° C
	Feuchtigkeit (ohne Kondenswasser) 5% ÷ 85%

 2900204549.02

DIERREGI SRL

VIA DELLA SCIENZA 5
41012 CARPI (MO) - ITALY
PHONE: +39.059.803.0103
FAX: +39.059.803.0113
COD. FISCALE E P.IVA:
03601330362

WWW.OMGA.IT

OMGA[®]
WOOD be nice.